

**DETAIL OF SEPTIC TANK**  
25 USERS (SCALE: 1:50)

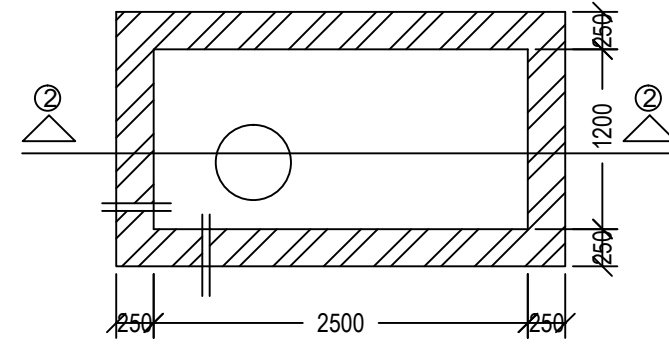

**SEMI UNDER GROUND WATER RESERVOIR**  
(CAPACITY: 600 GAL) (SCALE: 1:50)

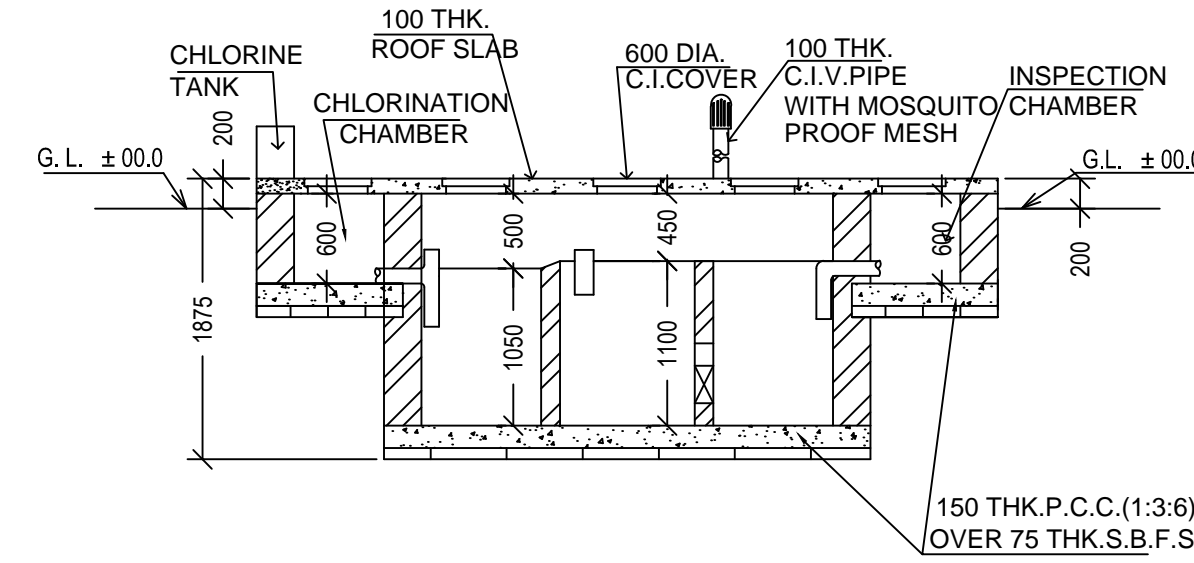

**SECTION AT 1-1** (SCALE: 1:50)

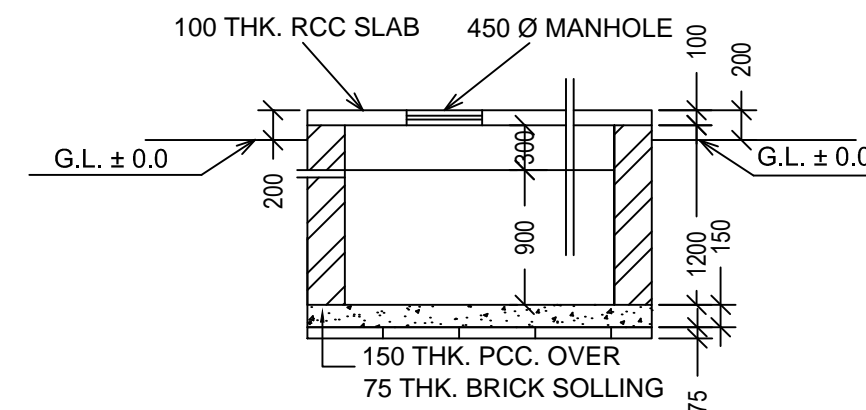

**SECTION AT 2-2**  
(SCALE: 1:50)

NOTES NO-1) DEPTH OF S.U.G.W.RESERVOIR & SEPTIC TANK SHOULD NOT BE GO BEYOND THE FOUNDATION OF THE BUILDING.  
2) ALL SORTS OF PRECAUTIONARY MEASURE WILL BE TAKEN AT THE TIME OF CONSTRUCTION OF BUILDING ALONG WITH SEPTIC TANK AND SEMI UNDER GROUND WATER RESERVOIR.

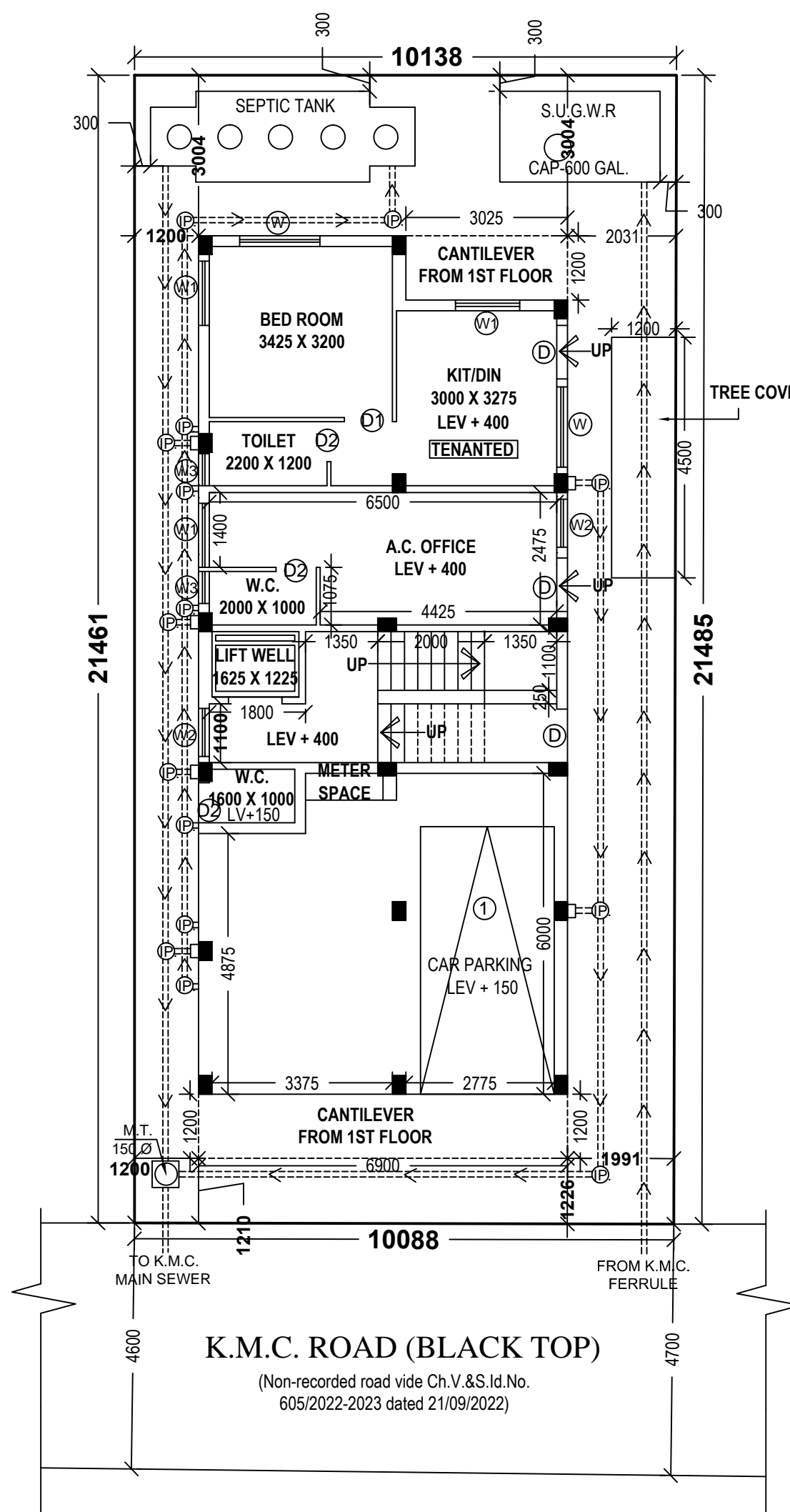

**GROUND FLOOR PLAN**  
SCALE: 1:100

